

# Fosroc Expoband One

(also known as Expoband H45)

Flexible expansion joint membrane

## Uses

Expoband One is a Hypalon membrane system which is designed to be bonded over movement joints or cracks in structures to prevent the passage of water. It is bonded in position using Nitomortar FCFS two-part epoxy adhesive. Expoband One is suitable for construction use and in repair/remedial applications

## Advantages

- Accommodates continuous and pronounced cyclic movement
- Excellent resistance to weathering
- Can be applied to dry or damp surfaces

## Standards Compliance

Water Regulations Advisory Service approved product.

## Description

Expoband One is an un-reinforced Hypalon membrane incorporating a central release tape, available in 1mm thickness and widths of 100mm and 200mm. The 1mm thick membrane is supplied in a 25 metre roll.

When longer lengths are required Expoband One can be joined by hot welding. It is bonded to the structure on both sides of the joint using Nitomortar FCFS two-part epoxy adhesive.

## Technical Support

Fosroc offers a comprehensive range of high performance, high quality technical products. In addition Fosroc offers a technical support package to specifiers and contractors which includes computer-aided design (CAD), standard details as well as on-site technical advice from staff with unrivalled experience in the industry.

## Design Criteria

Example of a reservoir wall, sealed internally with Expoband One

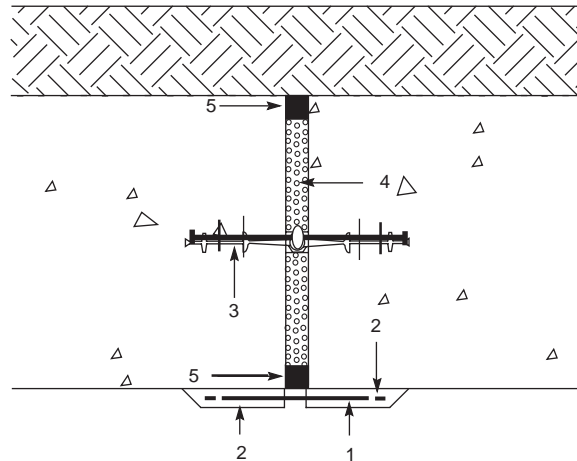

1. Expoband One
2. \*Nitomortar FCFS
3. \*Supercast Waterstop
4. \*Hydrocell
5. \*Thioflex 600 or Nitoseal MS600

\* Also available from Fosroc

## Maintenance

There are no special requirements, however any damage should be repaired by exposing the damaged area, cleaning the surface and replacing the strip.

## Properties

<b>Form</b>	: Elastomeric Strips
<b>Colour</b>	: Light Grey
<b>Density</b>	: 1.7 approximate
<b>Tensile Strength</b>	: 7 N/mm <sup>2</sup>
<b>Elongation at break</b>	: 400%
<b>Adhesion to concrete (with Nitomortar FCFS)</b>	: >tensile strength of substrate

## Specification clauses

Where indicated on the drawings, joints shall be sealed with Expoband One flexible expansion joint membrane system supplied by Fosroc. Expoband One shall be installed strictly in accordance with the manufacturer's printed instructions.

# Fosroc Expoband One

---

## Application instructions

### Joint preparation

Expansion joints must be packed with a firm, consolidated joint filler prior to laying the Expoband One. If necessary joints may be pre-sealed using a bituminous or elastomeric sealant. Ensure that any sealant used is capable of accommodating the anticipated joint movement. Where Expoband One has to be turned up parapets and the like, a splay should be provided so that the change in direction is smooth and progressive.

### Surface preparation

Concrete surfaces onto which the Expoband One is to be laid must be sound, frost and dust free. New concrete must be fully cured and free from curing compound. The concrete surface ideally should be wood float finished for the width of Expoband One and free from irregularities, with well designed arrises and no vertical misalignment between each side of the joint.

Prepare a suitable width of substrate 50mm wider than the membrane width selected. Sharp arrises should be ground down pencil round.

Remove all dirt, dust and laitance by rigorous wire brushing needle gun, abrasive blasting or grinding. Any spalling or honeycombing must be repaired prior to the application of the Expoband One system. Should the substrate be wet, dry gently with a gas torch or hot air blower. Dampness should not re-appear within 15 minutes for the substrate to be considered as being dry enough for the application of the Nitomortar FCFS. A maximum 25 mm width of masking tape applied adjacent to either arris will provide an increased unbonded width and greater movement potential if required.

### Priming of concrete

Priming of concrete is not normally required with the Nitomortar FCFS / Expoband One system. The use of Fosroc Primer MS2 should be considered where there could be doubt about porosity or condition of the concrete. Apply Fosroc Primer MS2 by brush, working well in, to a width of 25 mm either side of the membrane. Fosroc Primer MS2 should be left for about 40 to 60 minutes (depending upon temperature) to allow evaporation of the primer solvent prior to the application of the Nitomortar FCFS adhesive.

If the primer has been left longer than 8 hours or has become contaminated with dust, the surface must be reprimed.

The rate of cure of Fosroc Primer MS2 is temperature dependent. Ideally the substrate should be above 10°C to ensure a reasonable cure rate, however this primer can be applied when substrate temperatures are 5°C and rising.

### Preparation of the membrane

This operation is vital to the adhesion and performance of the Expoband One system. Measure and cut the length of Expoband One to suit the joint. The Expoband One Hypalon membrane must be prepared by thoroughly wiping both faces with Fosroc Solvent 102 and a clean cloth. DO NOT use excessive quantities of solvent. Allow 1 hour to dry before placing.

### Mixing and application of the adhesive

Transfer the entire contents of Part B of Nitomortar FCFS adhesive into the Part A container and mix thoroughly using a slow speed drill and Fosroc paddle stirrer for 4 minutes, stopping to scrape down the sides of the container. When mixed, the adhesive should be a uniform grey colour.

Use masking tape at extremities and along centre line of joint. Apply mixed Nitomortar FCFS using a serrated spreader. Apply to entire primed area; if not primed apply 25mm either side of membrane. Remove central masking tape immediately and position Expoband One membrane into the Nitomortar FCFS adhesive.

Roll firmly to displace trapped air and to ensure extrusion of Nitomortar FCFS through the edge perforations.

Apply a second layer of Nitomortar FCFS to the full width of the top surface of membrane. Remove central release film from membrane. Finally remove outer edge masking tapes and feather-edge the Nitomortar FCFS.

### Jointing the Expoband One membrane

The surfaces to be jointed must be clean and wiped with Fosroc Solvent 102 prior to jointing. For heat welded joints, a 50 mm overlap should be used. Welding is carried out using a proprietary hot air welding tool. The tool should be set to the correct heat output by trial to achieve a satisfactory weld.

The faces of the overlap are heated by moving the welding tool along the joint and, simultaneously, pressure should be applied by roller to the heated overlap to ensure that the faces are fused together. After application the Expoband One system should be allowed to cure for 28 days at 7°C before permanent contact with potable water.



# Fosroc Expoband One

---

## Ancillary materials and equipment

- Nitomortar FCFS.
- Fosroc Solvent 102.
- Fosroc Primer MS2.
- Slow speed drill and Fosroc paddle stirrer.
- Adhesive spreader with 2 to 3 mm serrations.
- Hot air welding gun and roller.

## Limitations

Joint layouts incorporating Expoband One should be kept as simple as possible to allow for site joints to be restricted to straight butt joints. Avoid complex changes of angle or skew giving rise to difficulty in jointing and installation.

## Estimating

### Supply

---

<b>Expoband One</b>	:	25m X 100mm X 1mm 25m X 200mm X 1mm
---------------------	---	--

---

## Coverage

### Nitomortar FCFS

(based on a 2mm spread of adhesive above and below the membrane)

---

<b>For 100mm wide</b>	:	5 to 6 linear metres per 2 litres Nitomortar FCFS
-----------------------	---	---

---

<b>For 200mm wide</b>	:	2.5 to 3.5 linear metres per 2litres Nitomortar FCFS Dependent upon surface roughness and film thickness
-----------------------	---	---

---

<b>Fosroc Primer MS2</b>	:	10m <sup>2</sup> /litre
--------------------------	---	-------------------------

---

The coverage figures are theoretical — due to wastage factors and the variety and nature of substrates, practical coverage figures may be substantially reduced.

## Storage

Expoband One should be stored in original unopened packaging, in cool dry conditions, away from sunlight. Fosroc Primer MS2 should be stored in accordance with the Highly Flammable Liquids and Liquefied Petroleum Gases Regulations 1972.

## Precautions

### Health and safety

#### Expoband One

There are no known hazards associated with this product in normal use.

#### Fire

Fosroc Primer MS2 and Fosroc Solvent 102 are flammable. Do not expose to naked flames or other sources of ignition. No Smoking. Containers should be tightly sealed when not in use. In the event of fire, extinguish with CO<sub>2</sub> or foam.

# Fosroc Expoband One

---

## Additional Information

Fosroc manufactures a wide range of complementary products which include :

- waterproofing membranes & waterstops
- joint sealants & filler boards
- cementitious & epoxy grouts
- specialised flooring materials

Fosroc additionally offers a comprehensive package of products specifically designed for the repair and refurbishment of damaged concrete. Fosroc's 'Systematic Approach' to concrete repair features the following :

- hand-placed repair mortars
- spray grade repair mortars
- fluid micro-concretes
- chemically resistant epoxy mortars
- anti-carbonation/anti-chloride protective coatings
- chemical and abrasion resistant coatings

For further information on any of the above, please consult your local Fosroc office - as below.

\* Denotes the trademark of Fosroc International Limited

† See separate data sheet



## Important note

Fosroc products are guaranteed against defective materials and manufacture and are sold subject to its standard Conditions for the Supply of Goods and Service. **All Fosroc datasheets are updated on a regular basis. It is the user's responsibility to obtain the latest version.**

## Head Office

**telephone:** (+9714) 2039699

**fax:** (+9714) 2859649

**email:** agf@fosroc.com

## Regional offices

Abu Dhabi, Al Gurg Fosroc  
Bahrain, YBA Kanoo  
Kuwait, Boodai  
Oman, Al Amana  
Qatar, Tadmur

**telephone:** 673 1779  
**telephone:** 17738200  
**telephone:** 4817618  
**telephone:** 24815080  
**telephone:** 4432365

**fax:** 673 1449  
**fax:** 17732828  
**fax:** 4832124  
**fax:** 24817554  
**fax:** 4419517

**email:** abudhabi@fosroc.com  
**email:** bahrain@fosroc.com  
**email:** kuwait@fosroc.com  
**email:** oman@fosroc.com  
**email:** qatar@fosroc.com

Al Gurg Fosroc LLC

Post Box 657, Dubai  
United Arab Emirates

[www.fosroc.com](http://www.fosroc.com)

